

# STAR TREK™

THE OFFICIAL STARSHIPS COLLECTION

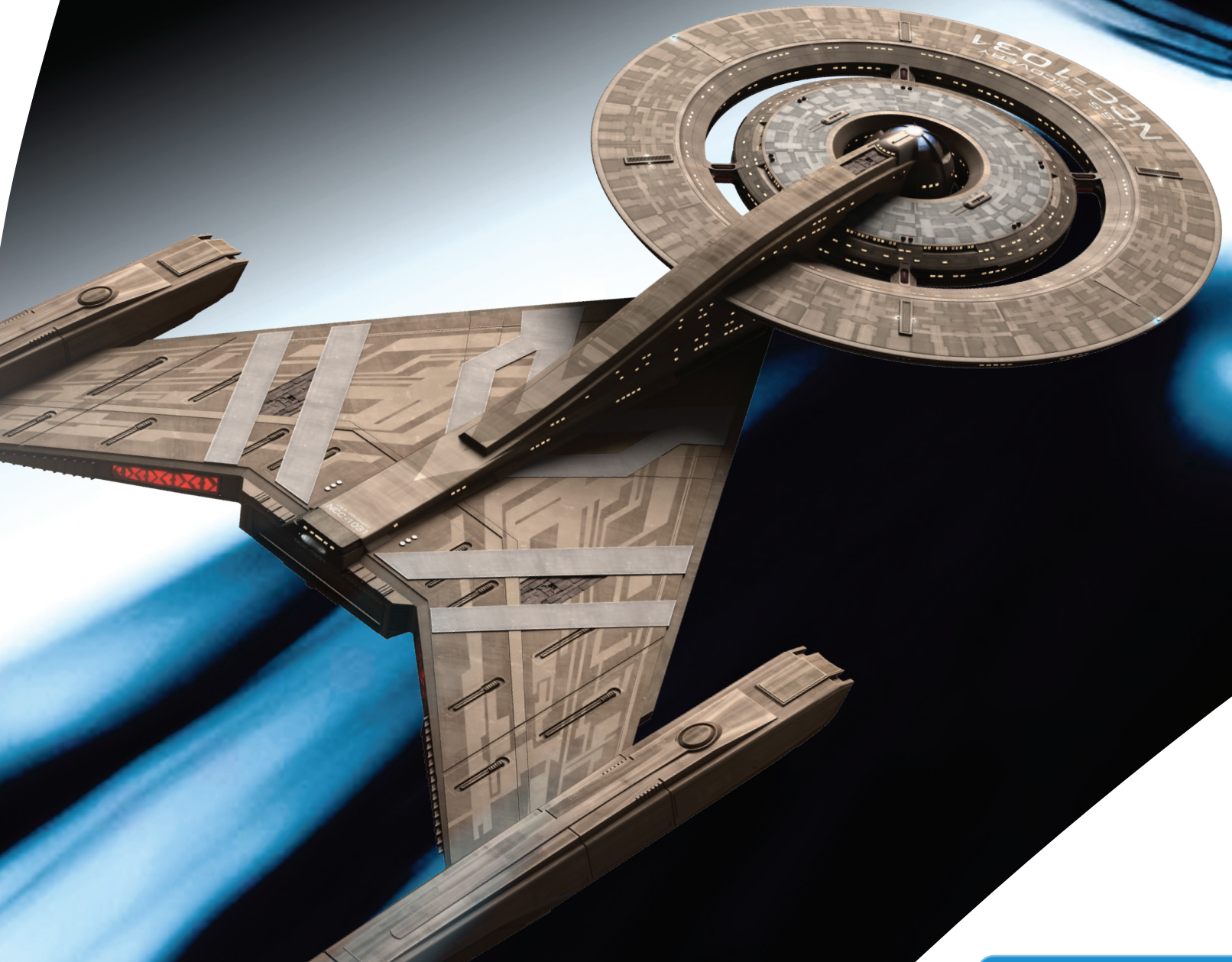

U.S.S. DISCOVERY  
**NCC-1031**  
SPECIAL ISSUE

CLASS: CROSSFIELD

LENGTH: 750.54 METERS

CAPTAINS: LORCA, PIKE

EXPERIMENTAL SPORE DRIVE

# Contents

04: PROFILE: *U.S.S. DISCOVERY*

06: DESIGNING THE SHIP

## Stand assembly:

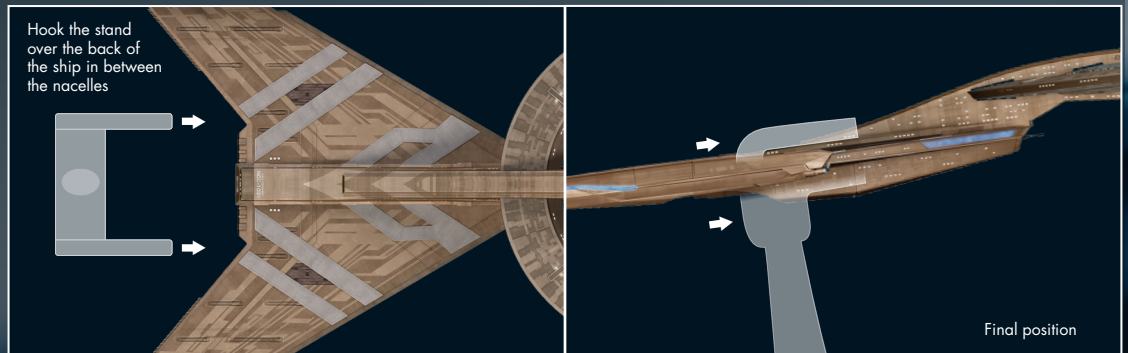

## ORDER ONLINE

Order binders, missing issues or other Eaglemoss products at:

[www.mycollectionshop.com](http://www.mycollectionshop.com)

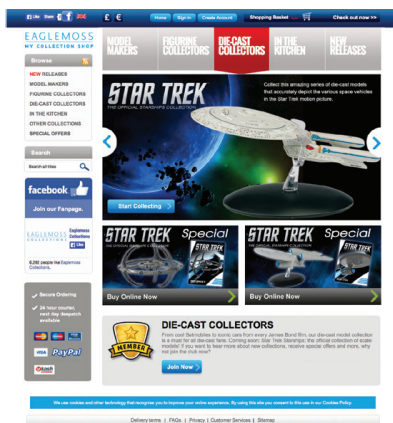

[www.mycollectionshop.com](http://www.mycollectionshop.com)

## EAGLEMOSS COLLECTIONS

Eaglemoss Ltd. 2020  
1st Floor, Kensington Village, Avonmore Road,  
W14 8TS, London, UK. All rights reserved.

™ & © 2020 CBS Studios Inc. © 2020 Paramount Pictures Corp. STAR TREK and related marks and logos are trademarks of CBS Studios Inc. All Rights Reserved.

STAR TREK – The Official Starships Collection is published fortnightly.

**DON'T MISS AN ISSUE:** Place a regular order with your magazine retailer.

**SUBSCRIBE** and receive exclusive free gifts – [www.startrek-starships.com](http://www.startrek-starships.com)  
Call 0344 493 6091

Post the subscription form included with issues 1 to 5

### BACK ISSUES

To order back issues:  
Subscribers call 0344 493 6091.  
Retail customers call 020 7429 4000

**UK DISTRIBUTOR:** SEYMOUR DISTRIBUTION LTD  
2 East Poultry Avenue, London EC1A 9PT  
Tel: 020 7429 4000

 **Find us on Facebook**

Join us online for competitions, updates and more!

Email: [info@seymour.co.uk](mailto:info@seymour.co.uk)  
Website: [www.seymour.co.uk](http://www.seymour.co.uk)

**UK CUSTOMER SERVICES:**  
0344 493 6091  
[startrek-ship@eaglemoss-service.com](mailto:startrek-ship@eaglemoss-service.com)

**Australia:** (02) 8378 7930  
[customer-service-australia@eaglemoss-service.com](mailto:customer-service-australia@eaglemoss-service.com)

**New Zealand:** (09) 928 4493  
[info@mycollectables.co.nz](mailto:info@mycollectables.co.nz)

**South Africa:** (011) 265 4307  
[service@jacklin.co.za](mailto:service@jacklin.co.za)

**Malaysia:** (03) 8020 7112  
[sales@allscript.com](mailto:sales@allscript.com)

**Singapore:** (65) 6287 7090  
[sales@allscript.com](mailto:sales@allscript.com)

**OVERSEAS BACK ISSUES**  
Place your order with your local magazine retailer.

Recommended age 14+.  
Warning! Collectable models.  
Not designed or intended for play by children.  
Do not dispose of in domestic waste.

[www.startrek-starships.com](http://www.startrek-starships.com)

# U.S.S. DISCOVERY

## SPECIFICATION

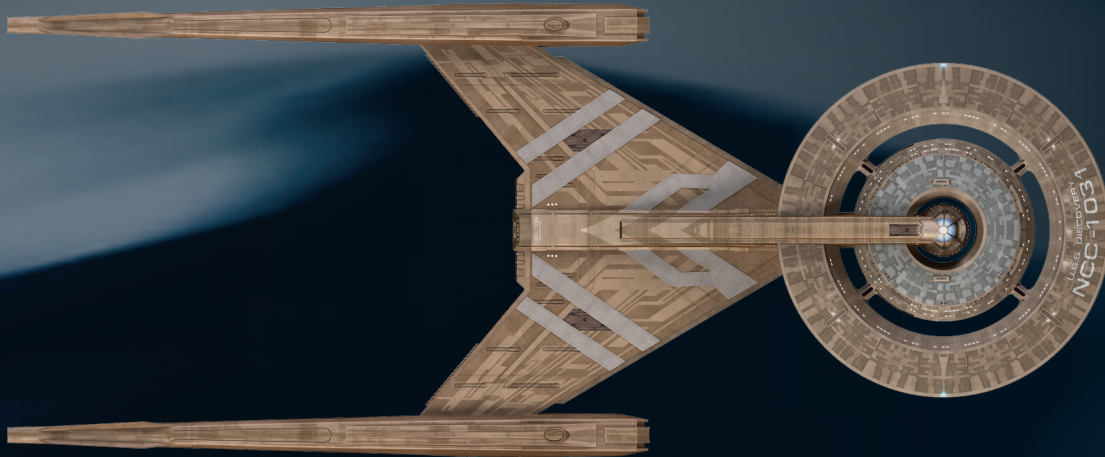

CLASS:	CROSSFIELD
LENGTH:	750.54 METERS
WEAPONRY:	PHASERS
	PHOTON TORPEDOES
PROPULSION:	FUSION REACTION IMPULSE DRIVE
	MATTER/ANTIMATTER WARP DRIVE
	SPORE DRIVE
CAPTAINS:	GABRIEL LORCA; CHRISTOPHER PIKE
LOST IN ACTION:	2257

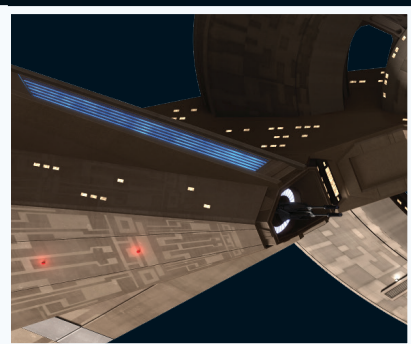
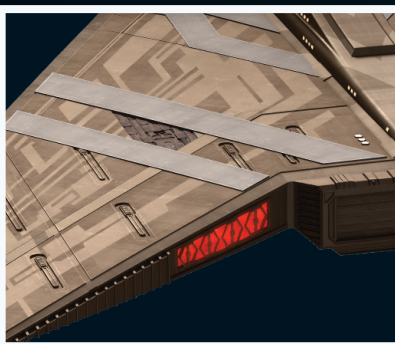



# U.S.S. DISCOVERY

The *Crossfield-class U.S.S. Discovery* was a revolutionary starship that was lost in action in 2257.



The *U.S.S. Discovery* was a *Crossfield*-class ship that was launched from the San Francisco Shipyards in the middle of the 23rd century. It played a major role in the Federation-Klingon war of 2256-57, scoring significant victories against the Klingons. It was instrumental in the end of the war when its crew helped L'Rell assume control of the Klingon Empire.

The *Discovery* was an experimental ship that was tasked with developing a spore drive that allowed it to make almost instantaneous journeys across vast distances by leaving normal space and travelling through the mycelial network. The technology was perfected in 2256, but it

depended on a human operator, and the technology was lost before it could be replicated. The ship was also fitted with conventional warp and impulse engines.

During the Klingon War, *Discovery* was under the command of Captain Gabriel Lorca. When he was lost in action in circumstances that are classified, Christopher Pike assumed temporary command to investigate a series of mysterious signals. Pike had just returned to the *Enterprise* when *Discovery* was lost, presumed destroyed, fighting a fleet of Section 31 ships under the command of the AI Control.

► The *U.S.S. Discovery* entered service under the command of Captain Gabriel Lorca, who had previously commanded the *U.S.S. Buran*.





# DESIGNING THE U.S.S. DISCOVERY

Even though it wouldn't appear until the third episode, the *U.S.S. Discovery* was the foundation of *STAR TREK*'s new design aesthetic.

**W**hen *DISCOVERY*'s co-creator, Bryan Fuller started to think about the series, he knew that he wanted the show to look radically different to anything we had seen before, and inevitably the *Discovery* itself would be

at the center of this. "When I sat down with the art department," he remembers, "I said 'OK we're designing a new ship and it's going to be an opportunity to do something interesting and different.' I wanted to pay as many homages to

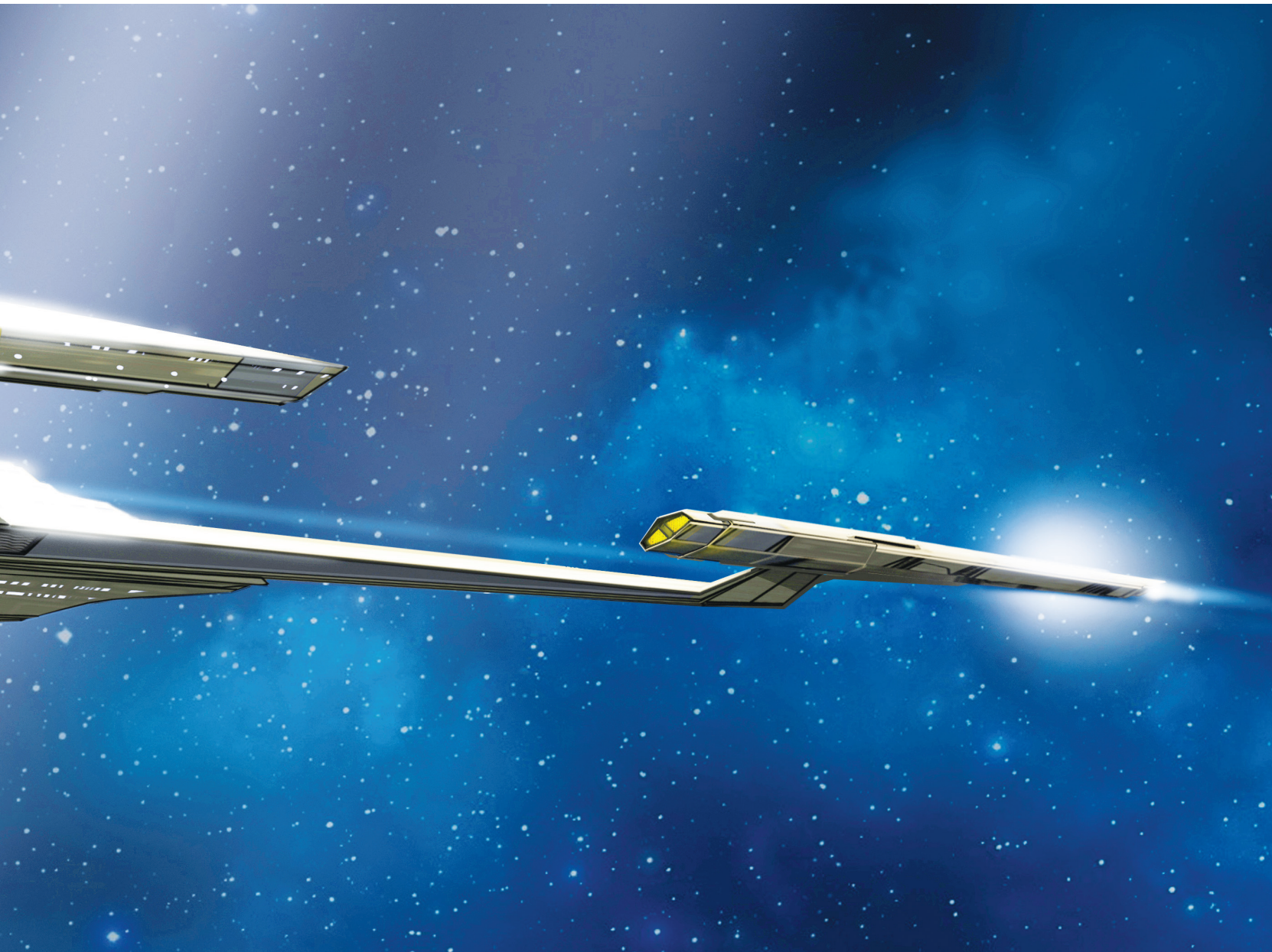

the original series as possible, but we wanted to use more modern elements for the ships. *STAR TREK* couldn't look like it did in 1969, because we don't look like that future now and it's only 50 years later. I wanted to create a new aesthetic for *STAR TREK*."

Fuller and his production designer Mark Worthington found inspiration in some work that had been done by legendary designers Ken Adam and Ralph McQuarrie in the 1970s for a *STAR TREK* movie called *Planet of the Titans*. A lot of design had been done, but the film was never made. As Fuller explains there were a series of drawings that showed a redesign of the *Enterprise* with a

triangular body. "Their *Enterprise* was a fantastic ship that had a distinct silhouette. It was different from the traditional saucer and nacelles, and it had a bit of that blocky seventies vibe. I liked that; and I liked the silhouette."

#### CINEMATIC INSPIRATION

Those drawings became something of a touchstone for Fuller's approach to the entire series. He responded to the seventies design aesthetic and he wanted to embrace the epic approach that Ken Adam had established as the production designer of most of the James Bond

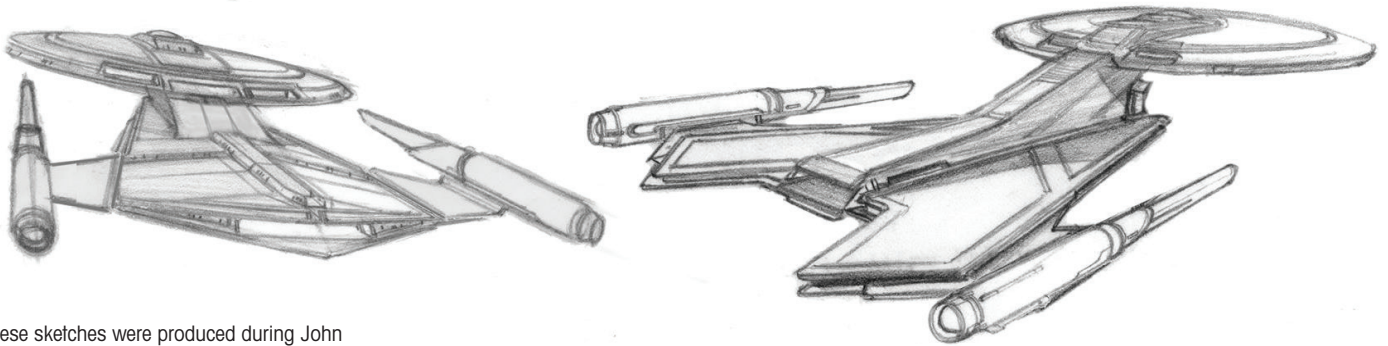

► These sketches were produced during John Eaves' first day on the show. Over the months that followed he sketched dozens of versions of the *Discovery* with varying shapes and features.

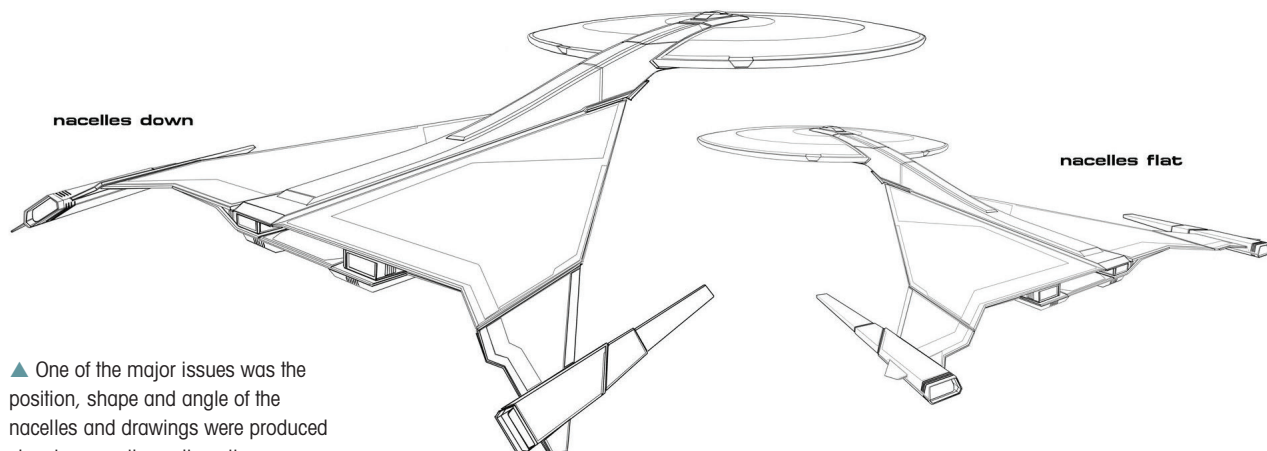
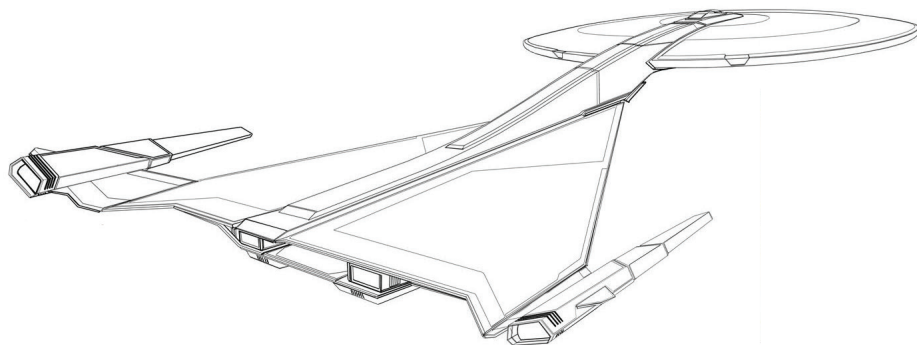
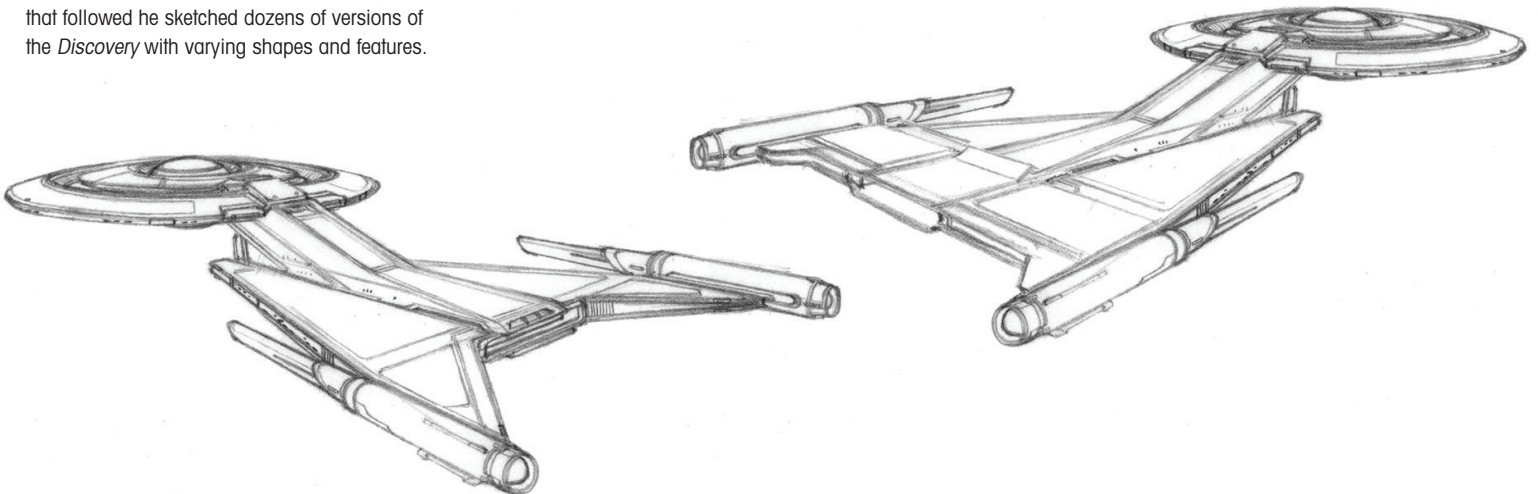

▲ One of the major issues was the position, shape and angle of the nacelles and drawings were produced showing countless alternatives.



movies. "I'm very aesthetically driven," Fuller says, "and I liked having the idea of using that era as an inspiration. We talked quite a bit about Ken Adam's designs for Bond. In my original story *DISCOVERY* was meant to be a spy story so it made sense."

After Fuller and Worthington had agreed on their basic approach to the look of the *Discovery*, concept artist John Eaves was brought onboard to design the ship. He was given three sketches and told to use them as inspiration. Two of them were produced by Adam and McQuarrie. The third sketch was by a man called Paul Christopher. "He'd done a real quick, sketch," recalls Eaves. "It was just a whole bunch of basic stuff – a little Federation stuff, a little Klingon stuff. He had that on the wall and it was a bit of a departure from the McQuarrie and Adam one."

### SECRET MISSION

After viewing Eaves' first round of sketches of *Discovery*, Fuller added a critical requirement – under no circumstances should the resulting ship feature round nacelles. "Bryan just said that he wanted to see something different," recalls Eaves. "He didn't explain why – all I knew was that he wanted a whole different look to the nacelles."

Fuller reveals that there was a very good reason behind his request: later in the series, Lorca's ship was going to disguise itself. "*Discovery* needed to be able to jettison its saucer section and transform itself so it could pose as a Klingon D-7 battle cruiser. That was why we didn't want to have round nacelles. It was going to be used to

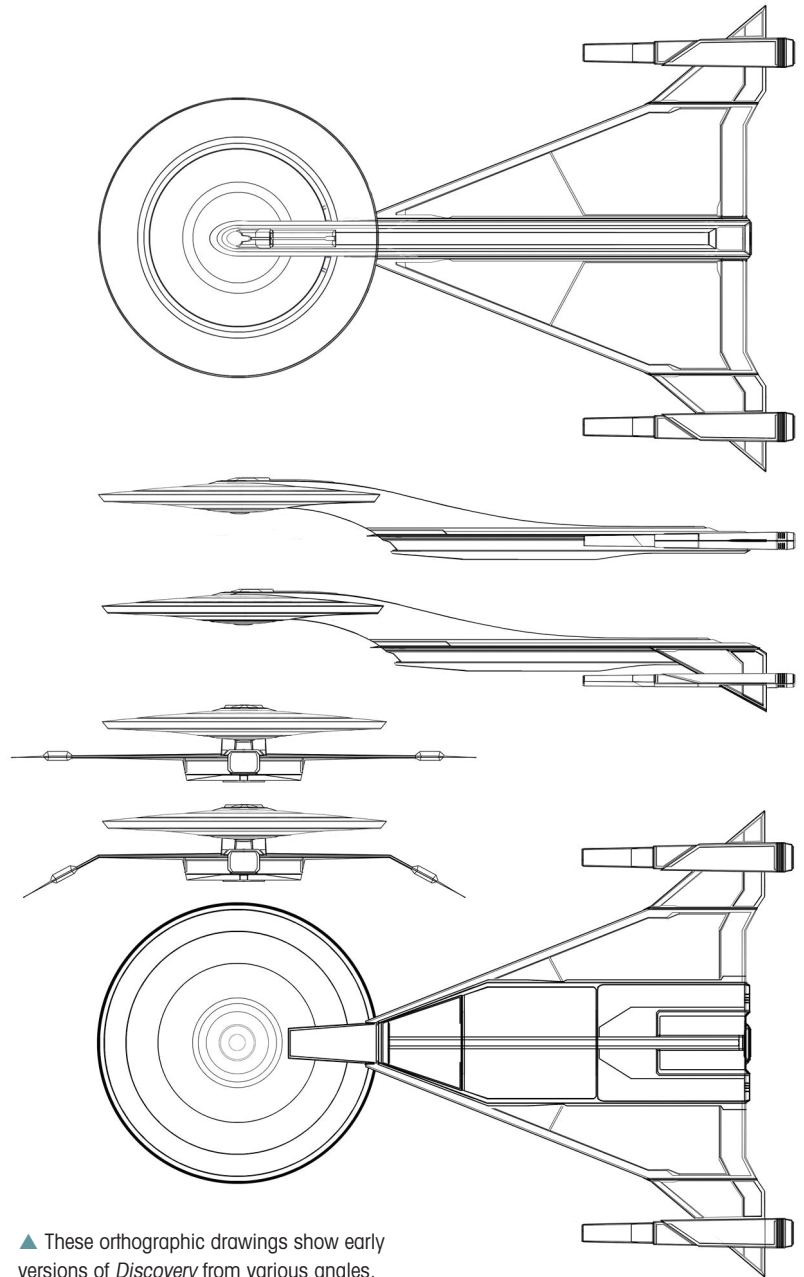

▲ These orthographic drawings show early versions of *Discovery* from various angles.

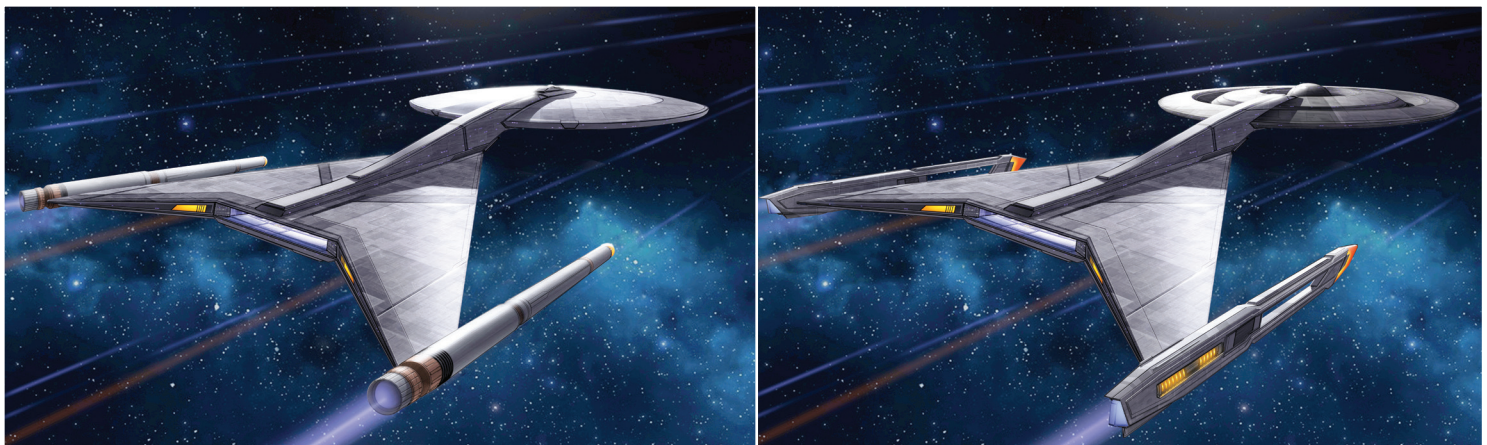

▲ *DISCOVERY*'s co-creator Bryan Fuller insisted that he didn't want the ships in the new show to have round nacelles. Eaves was concerned that this wasn't consistent with Kirk's ship or the NX-01, and he produced drawings that showed what round nacelles might look like. He also looked at new and unusual shapes that had never been used before.

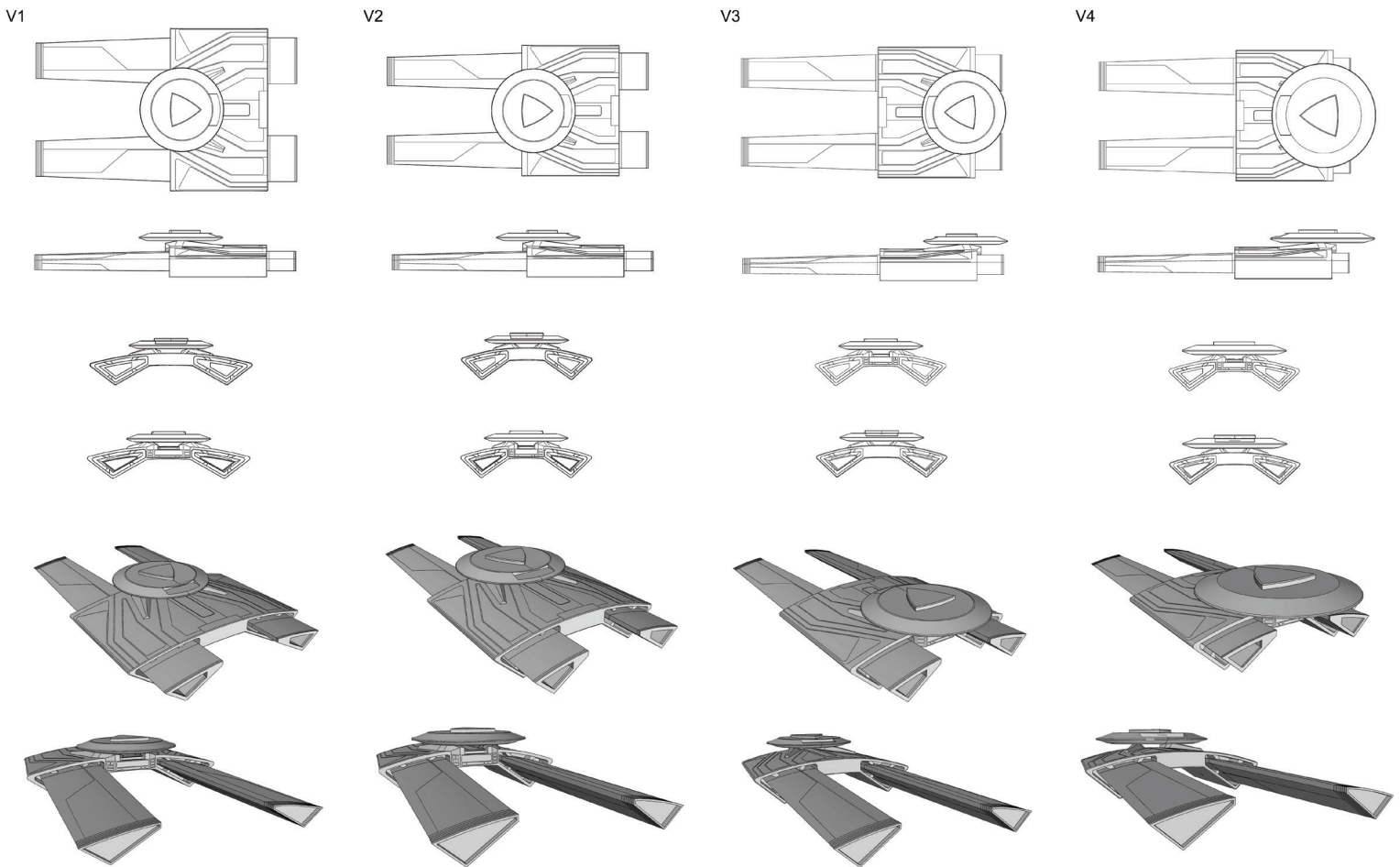

▲ This unusual design was based on a sketch that was produced before Eaves joined the show and is a rare departure from the approach that was established by Ken Adam and Ralph McQuarrie.

infiltrate Klingon space. The outer ring of the saucer would have been jettisoned and become a gyroscopic space station, *2001* style. The inner part of it would have spun around inside the outer ring to generate gravity.

"The doughnut in the middle of the saucer would have become the head of the D-7 battle cruiser. The nacelles would crank down when it jettisoned the saucer section, and the ends would have come off so they looked like Klingon nacelles. That was really a big impetus for a lot of the evolution of the design of the *Discovery*."

#### THE VALKYRIE INFLUENCE

Eaves went back to work producing sketch after sketch. However, nothing hit the mark. "Bryan would be fine with aspects of the sketches, but that was as far as it went. I just couldn't figure out what he wanted to see," Eaves says.

Around this time, Eaves brought up the idea of

incorporating elements from the XB-70 *Valkyrie*, a prototype United States Air Force bomber from the 1950s. "We used that as kind of a basis for our design," he recalls. "It has the gooseneck; it has that little 'A' shape in the back. When I showed it to the producers, they really liked that approach. The *Valkyrie* had these wingtips that do all kinds of movement stuff. You could have it on a flat profile for standard flight and they could do a little more aggressive wing-drop for the work flight."

But while Fuller liked the direction they were taking, he was still adamant that the nacelles weren't what he was looking for. "We probably did, gosh, five or six months of *Discovery* drawings," says Eaves. "But, try as we might, we just couldn't get those nacelles the way that Bryan wanted."

As he was working on the design, Eaves produced several color passes. "At the beginning, we were doing bare metal," he recalls. "We were trying to do a tie between the NX-01 and the TOS

PLAN  
SCALE : NTS

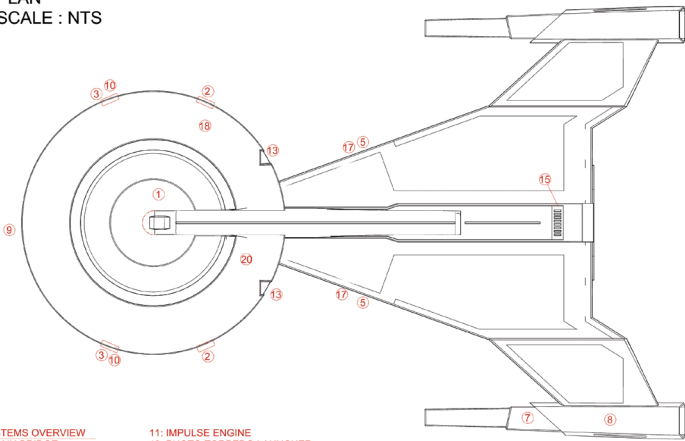

- SYSTEMS OVERVIEW
- 1: MAIN BRIDGE
  - 2: CARGO BAY DOORS
  - 3: AIRLOCK
  - 4: SENSOR DOME
  - 5: SHUTTLEBAY
  - 6: BOW PHASER ARRAY
  - 7: WARP NACELLE
  - 8: WARP COILS
  - 9: NAVIGATIONAL DEFLECTOR
  - 10: HARD CONNECT POINT
  - 11: IMPULSE ENGINE
  - 12: PHOTO TORPEDO LAUNCHER
  - 13: SAUCER IMPULSE ENGINE
  - 14: AFT PHASER ARRAY
  - 15: AFT PHOTON TORPEDO LAUNCHER
  - 16: MAIN DEFLECTOR
  - 17: ESCAPE PODS
  - 18: DISC LIFT EGRESS
  - 19: BRIG
  - 20: SICK BAY
  - 21: ENGINEERINGR

PERSPECTIVE

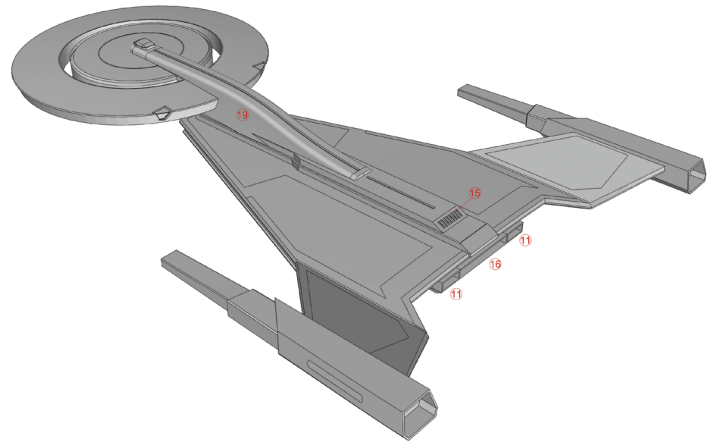

SIDE ELEVATION

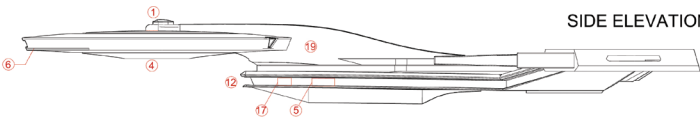

FRONT ELEVATION

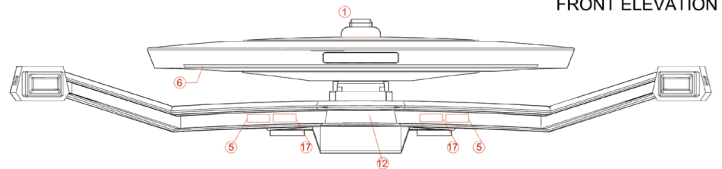

SECTION



BACK ELEVATION

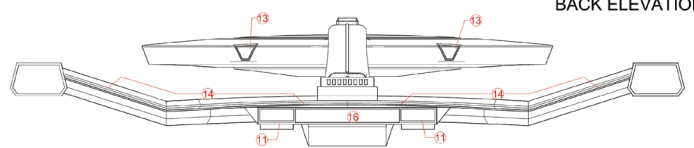

▲ At every stage, the team thought about where all of the *Discovery*'s key components should be, and they produced drawings that called them out.

◀ Other members of the art department pitched in to take a pass at the design. This version was produced by Ryan Dening.

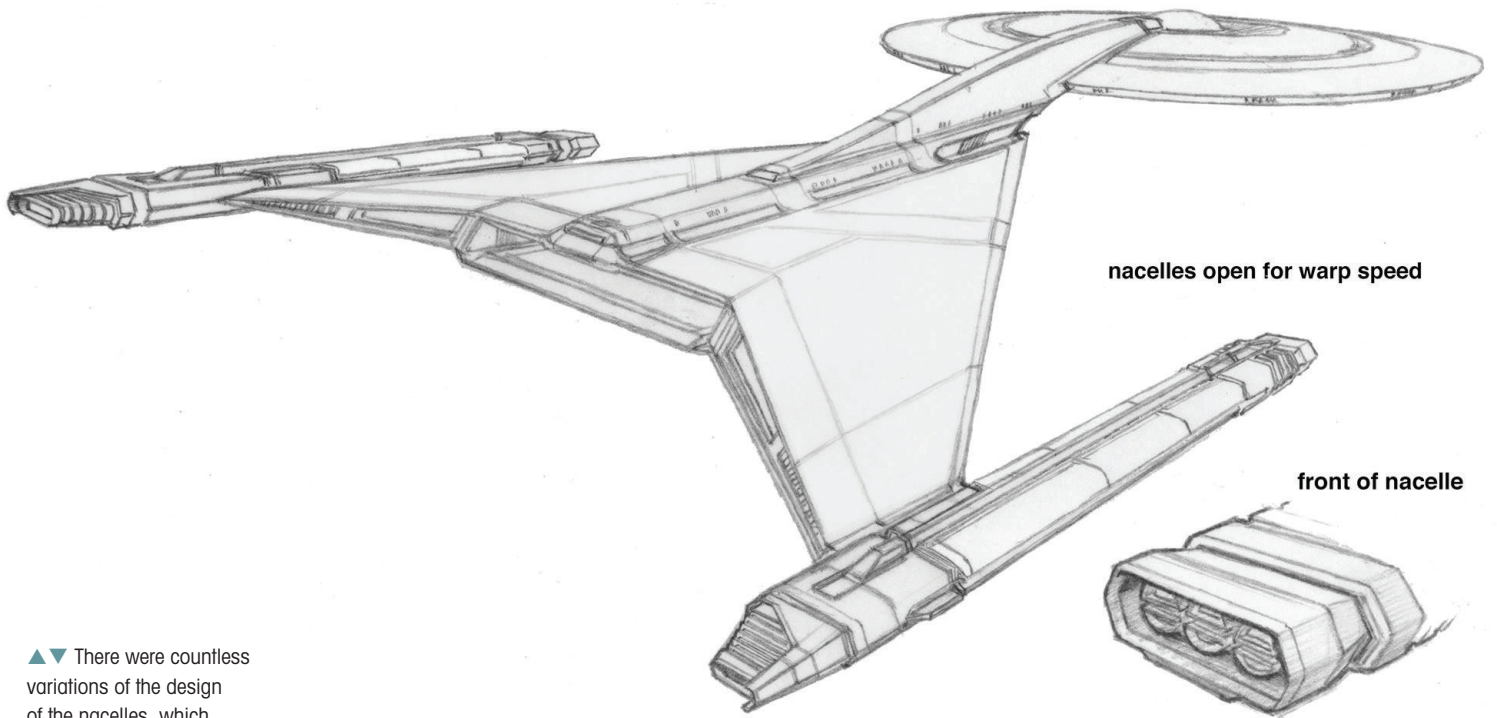

nacelles open for warp speed

front of nacelle

▲▼ There were countless variations of the design of the nacelles, which Eaves had been told would be experimental. In this version the inner workings were exposed when the ship went to warp.

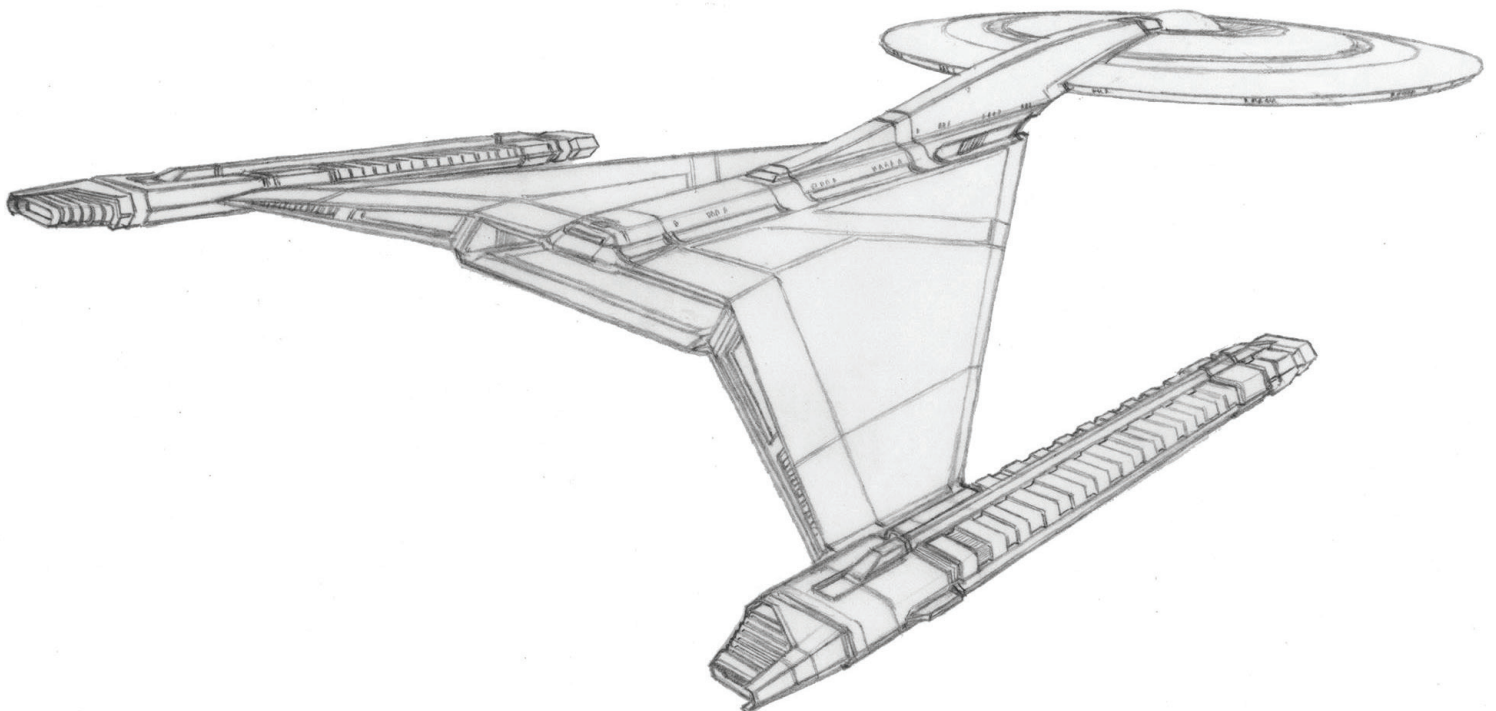

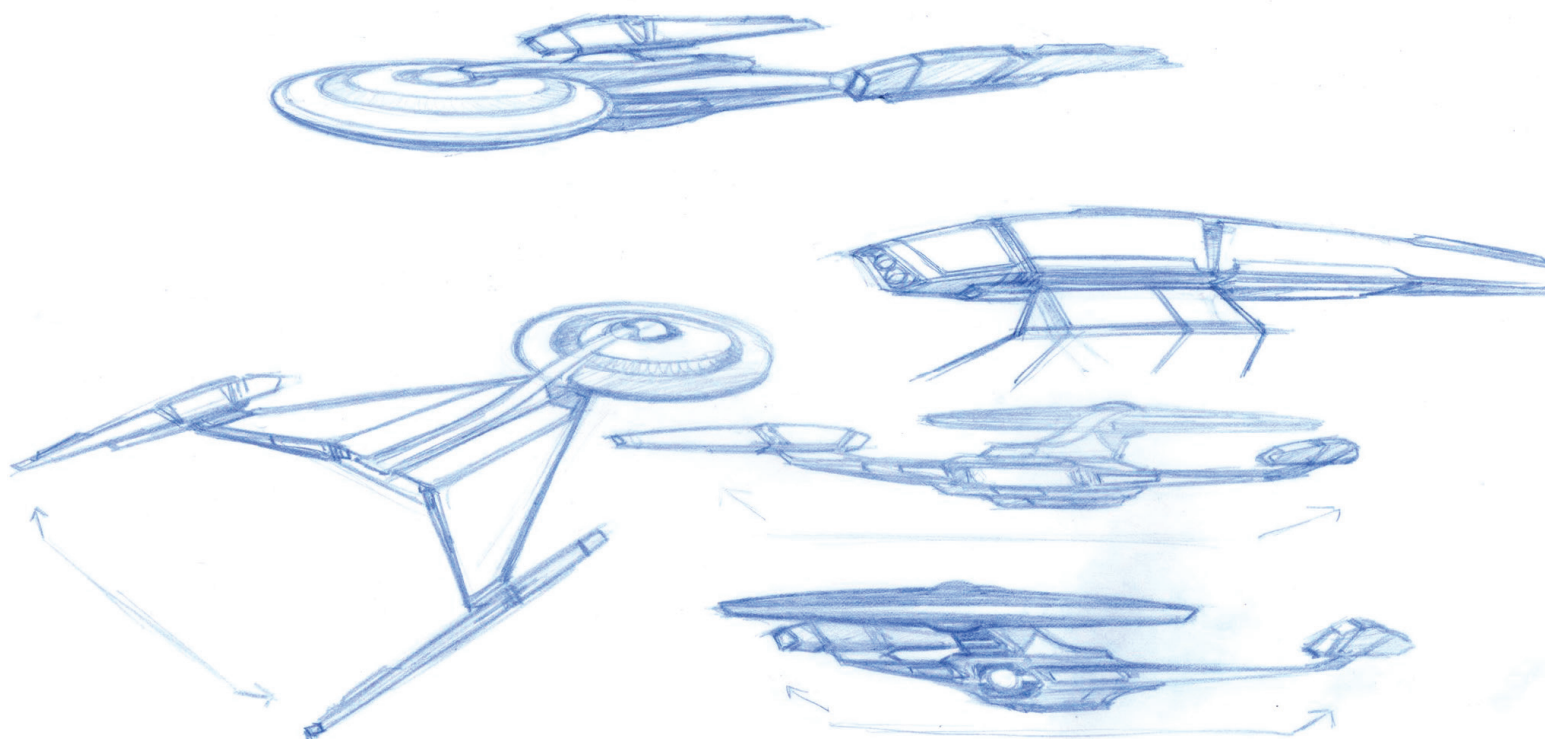

*Enterprise*, where it was a combination of bare metal and a paint scheme. It looked really nice – there were blue/gray steel color patterns. Bryan came in one day and said, 'Naw, let's make it bronze or a gold.'"

Fuller reveals that there were two thoughts behind this request. "When we talked about Ken Adam's work, we looked at James Bond's Lotus. The first time he had that car it was white, but later

on he had a copper version. The seventies felt like an interesting era for color schemes and that would be an interesting influence. But as well as trying to create a different look for the show, we were mindful of the science. Because of *Discovery's* need to go where no ship had gone before, we thought it would need an extra layer of protection so we made it gold plated to help protect it from higher levels of radiation. That

▲ Even when the design of the ship was almost done, there was still uncertainty about the shape and size of the nacelles.

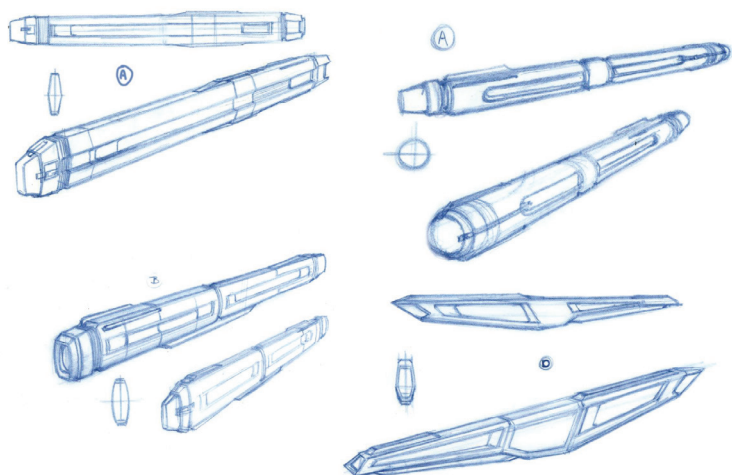

▲ The nacelles went through countless permutations, sometimes this even involved separate study drawings that ignored the rest of the ship.

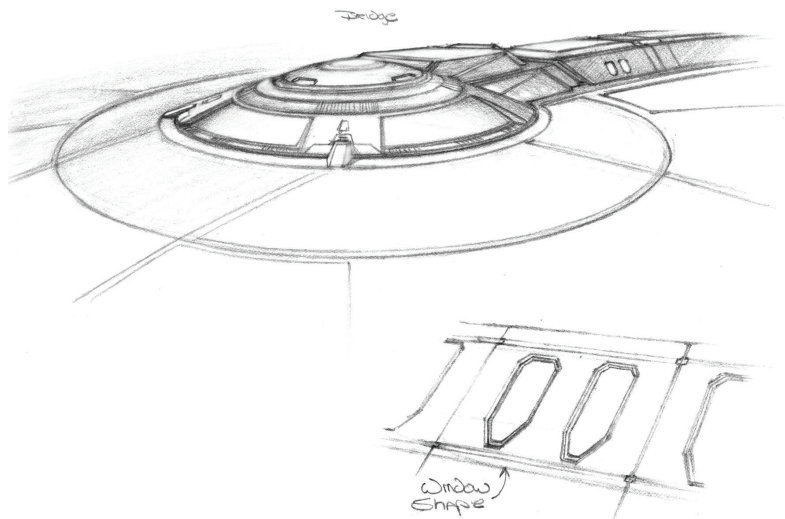

▲ The mechanics of the saucer was another challenge. Fuller always wanted it to break up into separate parts so the ship could disguise itself.

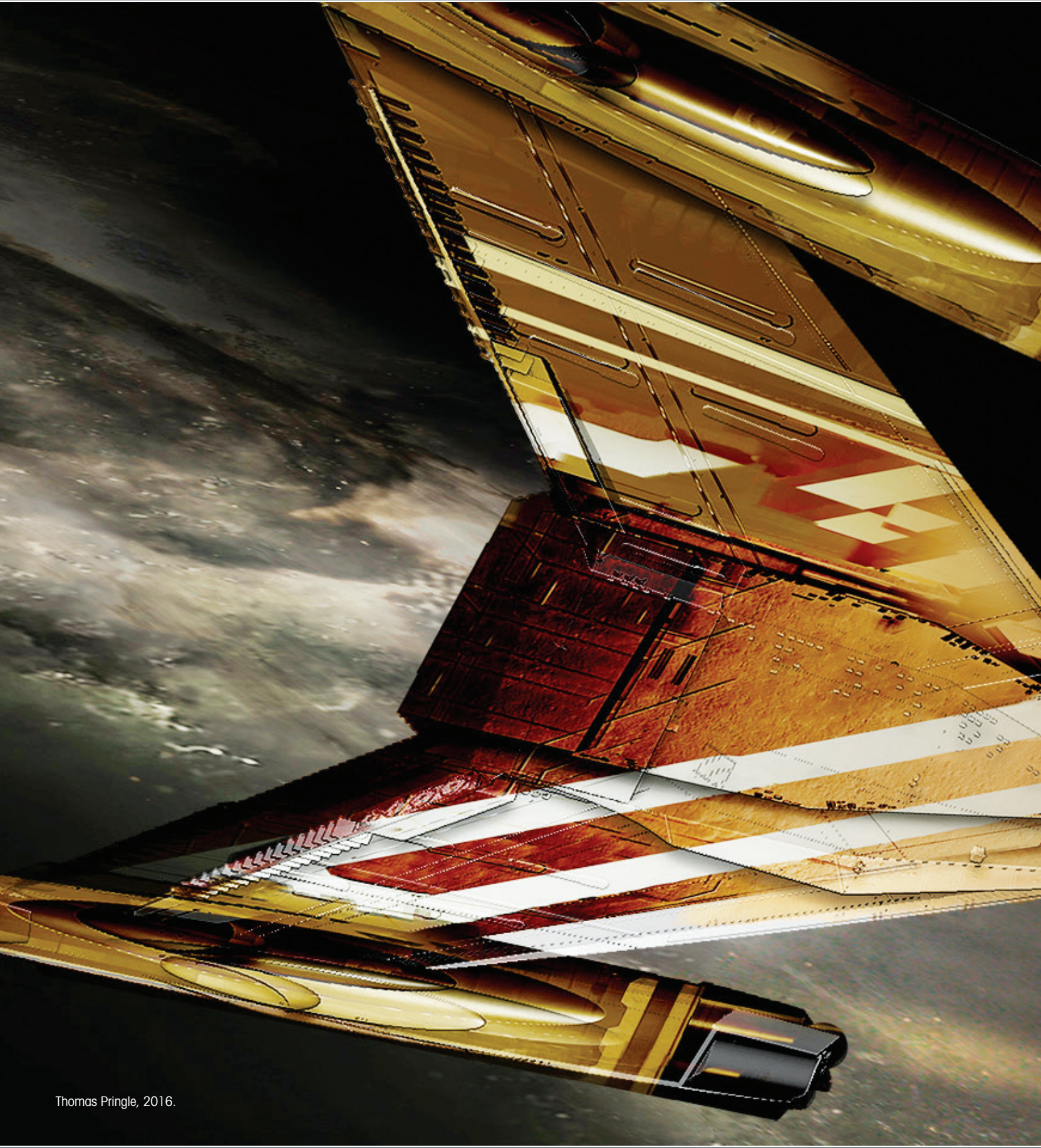

Thomas Pringle, 2016.

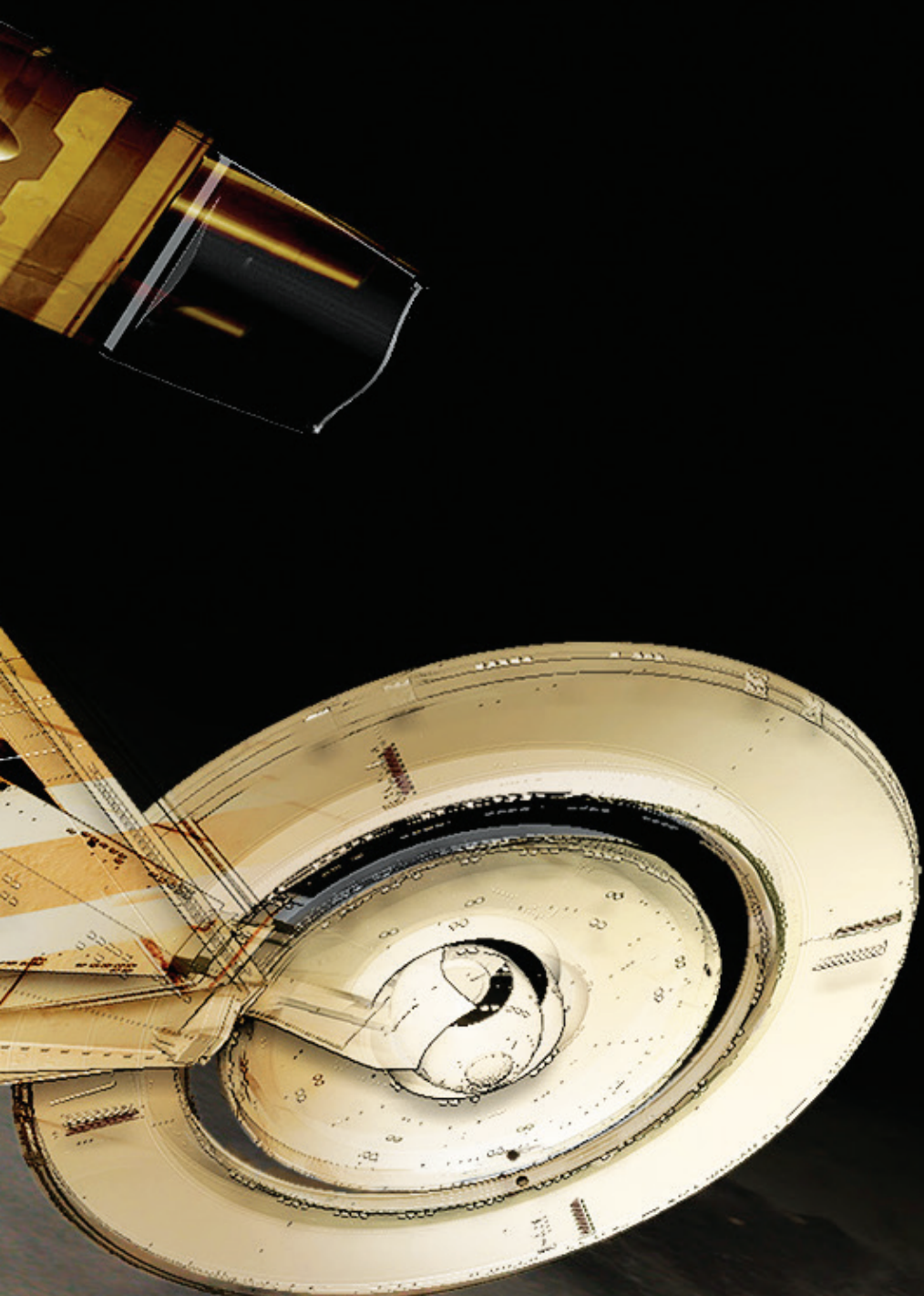

◀ Thomas Pringle produced drawings showing a radically different approach to the surface, adding bold stripes that he'd originally developed for the shuttle.

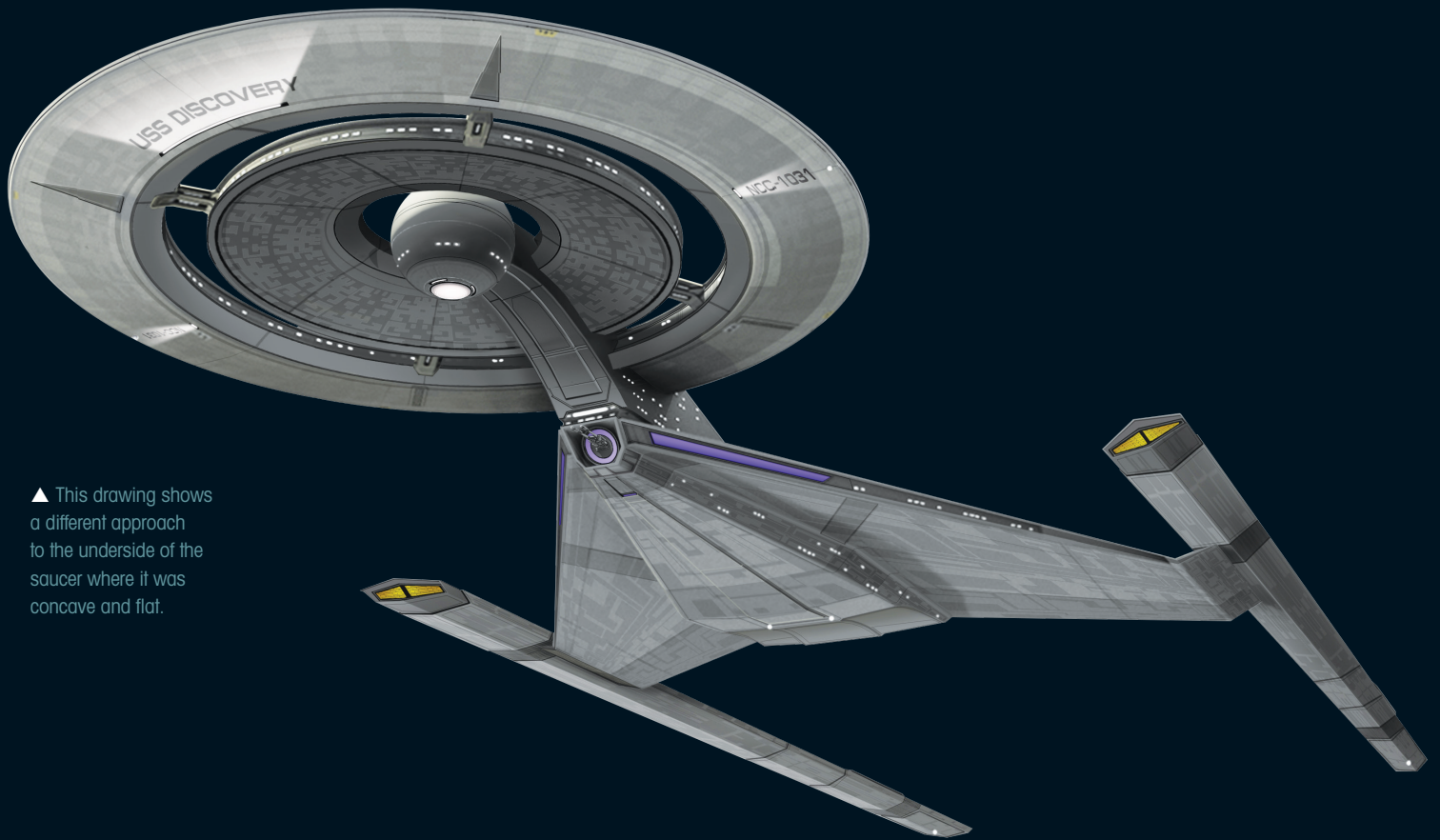

▲ This drawing shows a different approach to the underside of the saucer where it was concave and flat.

was something we considered doing for the uniforms too. "

Eaves and another member of the art department, Thomas Pringle, experimented with a variety of color schemes. "We did different versions.," Eaves says. "The gold that Bryan liked in the beginning was almost too much - it was especially bright. We did a comparison with a deeper, bronzier kind of look and he liked that, so that went through."

### GOING PUBLIC

The decision was taken to unveil the ship at the 2016 San Diego Comic-Con, while it was still being worked on. "They made a real quick, rough model which wasn't really based on anything but old sketches," recalls Eaves. Fuller certainly wasn't satisfied with the design at this point and work continued after Comic-Con "We had the body and the saucer down," Eaves says, "and we had started talking about having the ball in the center. We also had the segmented saucer - it wasn't open in the Comic-Con version, it had kind of a cone-shaped pattern going through the center of it. Then I did a version where it was open and they

really liked that a lot. They went, 'That's pretty cool. We'll have that as kind of a new basis of what we're going to do from there on out.'"

At this point, Eaves was still working on the nacelles. "I was doing nacelles that were forward, that were reversed. They were all on short pylons like the McQuarrie one, except that they were angled. They had a much sleeker taper to the way they looked."

▼ Eaves produced these drawings to show what all the details on the surface of the ship looked like in the DISCOVERY era.

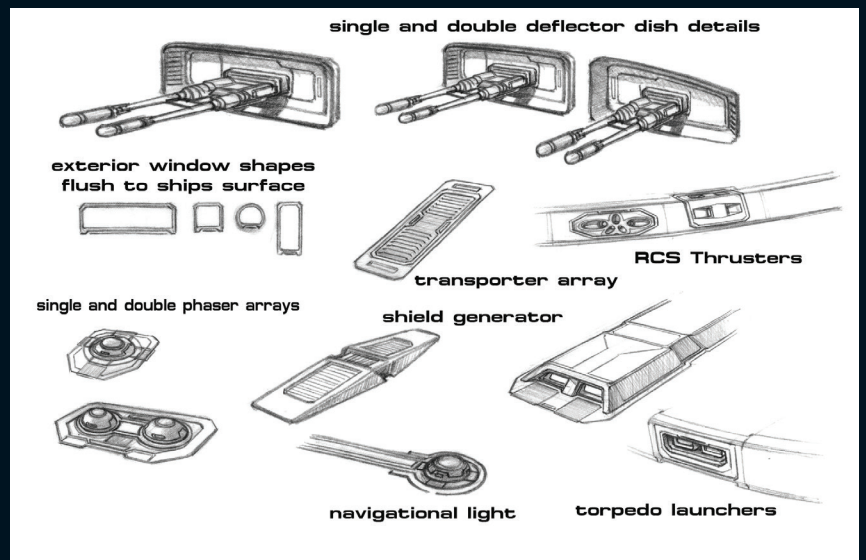



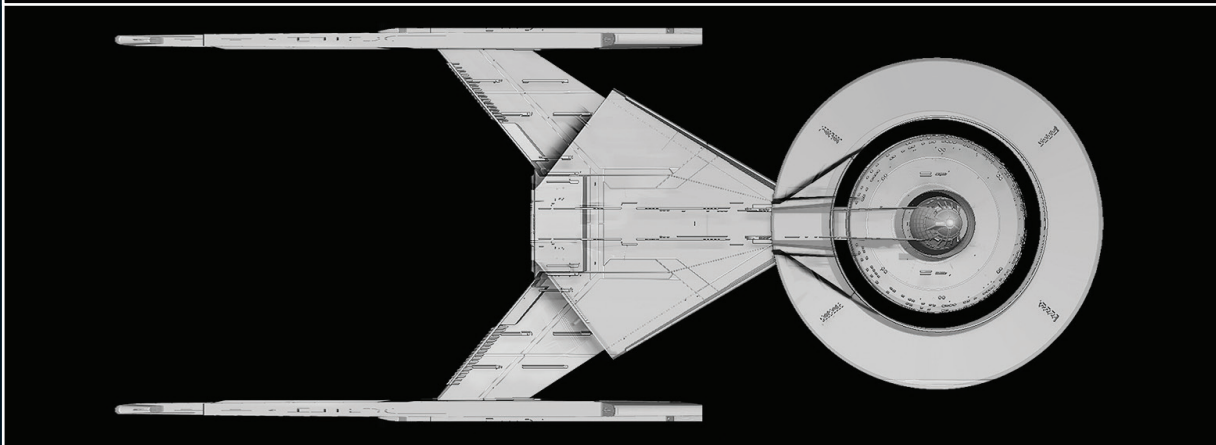
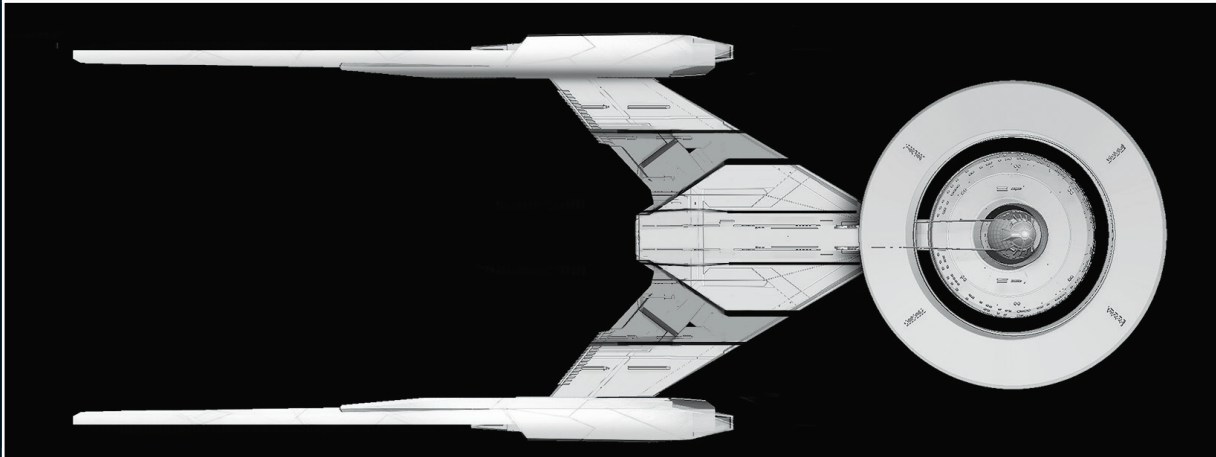
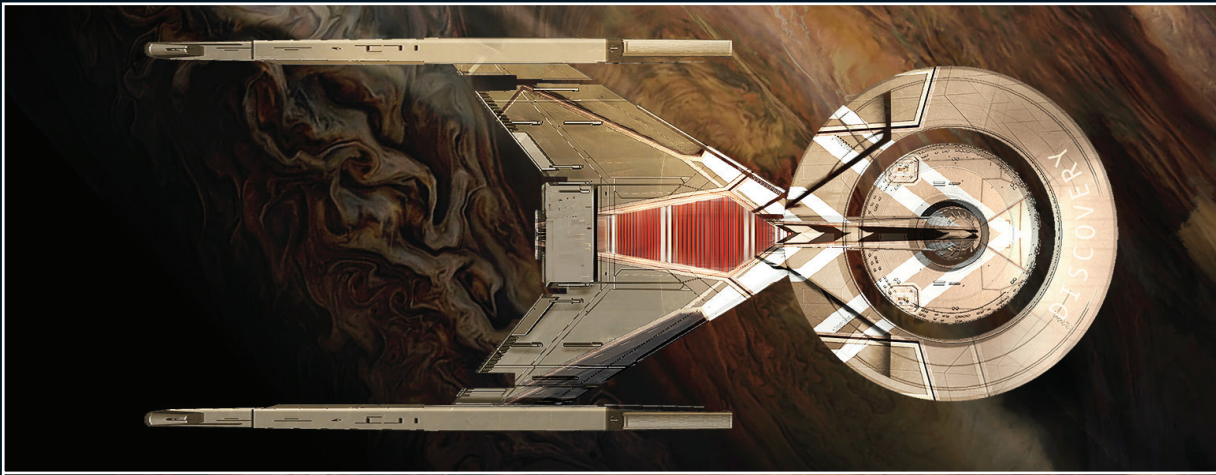

◀ Even late in the day, the art department were still experimenting with different ways of altering the ship's proportions.

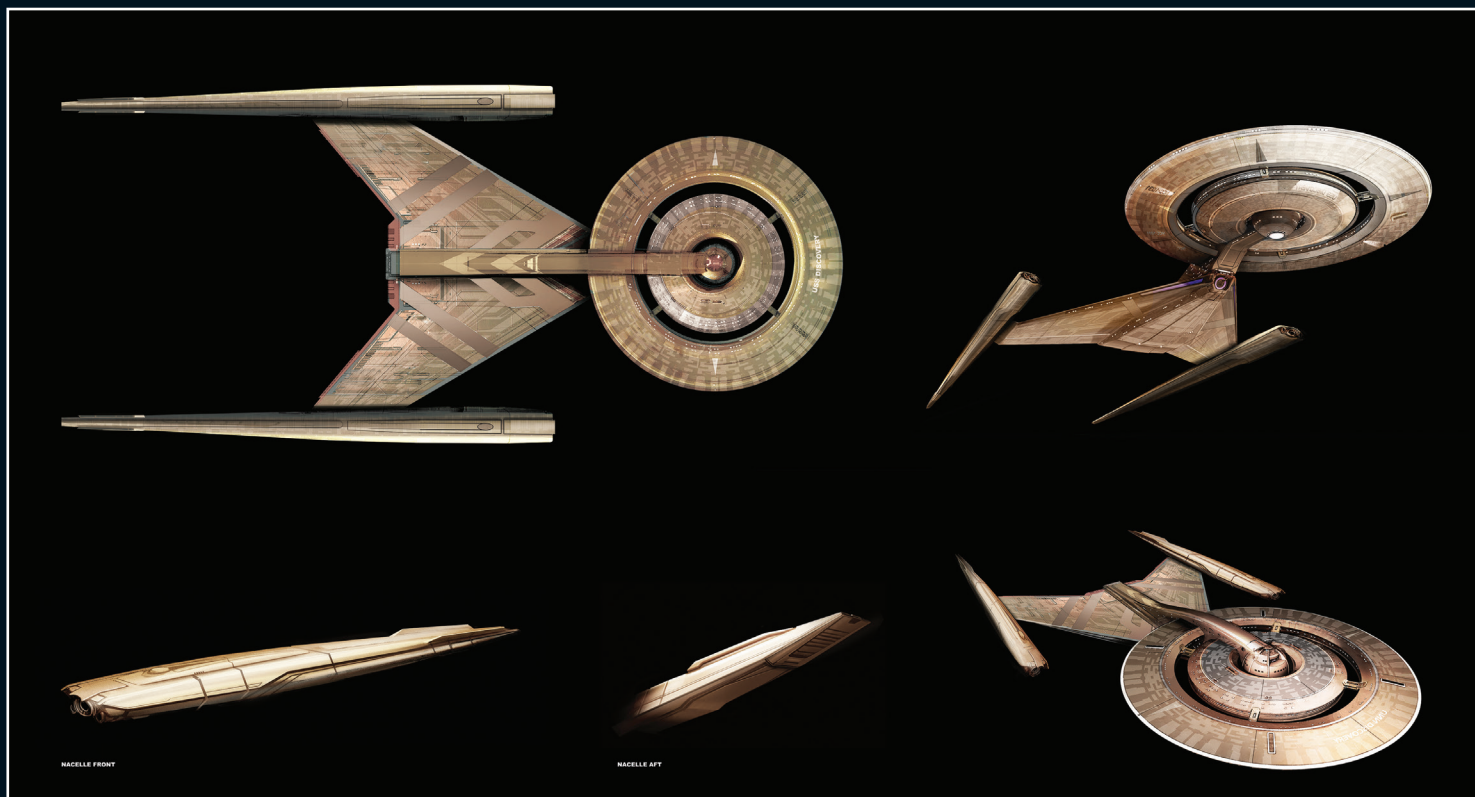

▲ This is one of the last color studies Pringle produced and it is very close to the final effect.

By October 2016 Fuller had stepped away from the project and production designer Todd Cherniawsky was heading up the art department. It was at this point that Eaves' latest design was approved and sent to the CG company who sent back roughs for him to adjust.

"That model was basically a reworking of the one from the trailer they showed at Comic-Con," explains Eaves. "By then we had gone through the whole thing with exceedingly long nacelles, with short nacelles, with boxy nacelles. Keeping the *Valkyrie* in mind the whole time. Finally, we decided on longer nacelles. It was probably December at this point, and that was when they started talking about the spore drive and the special warp."

Eaves suggested naming all the Starfleet ships after various test pilots and astronauts. The *Discovery* was named for Scott Crossfield, who was an X-15 test pilot.

#### PERFECTING THE PAINTS

The paint scheme for *Discovery* was finalized by Pringle. "He took over doing that final paint scheme based on what I had come up with," Eaves remembers. "He did a nice rendition of it. He made the stripe patterns on the top. I thought that

break up was kind of cool. Originally, it was just a paint scheme but it's actually a raised detail."

Meanwhile, Scott Schneider had been brought on to work on the modeling. He concentrated on the shuttle bay, and along with Eaves, worked on the saucer rotation. "A lot of this had been done in the CG department and I didn't have to do those drawings," Eaves says. "The first notes we got were that the rings spun, but that just didn't work mechanically. I designed it so the top surfaces were what did the rotation, as opposed to the entire ring."

All the Starfleet ships Eaves designed, including the *U.S.S. Discovery*, ended up having chunky-looking deflectors with a double antenna. According to Eaves, this was a happy accident. "Illustration-wise it was smoother," he explains. "The chunkiness came from the CG department. Pierre Drolet was doing the model in the beginning, but he moved on. I don't think he had time to smooth out all the details he was working on and it just stuck. It's definitely on the heavier end of things."

Eaves' painstaking work paid off: the final version of *Discovery* was clearly an evolution of the work that had been done in the seventies but was also new and radically different.

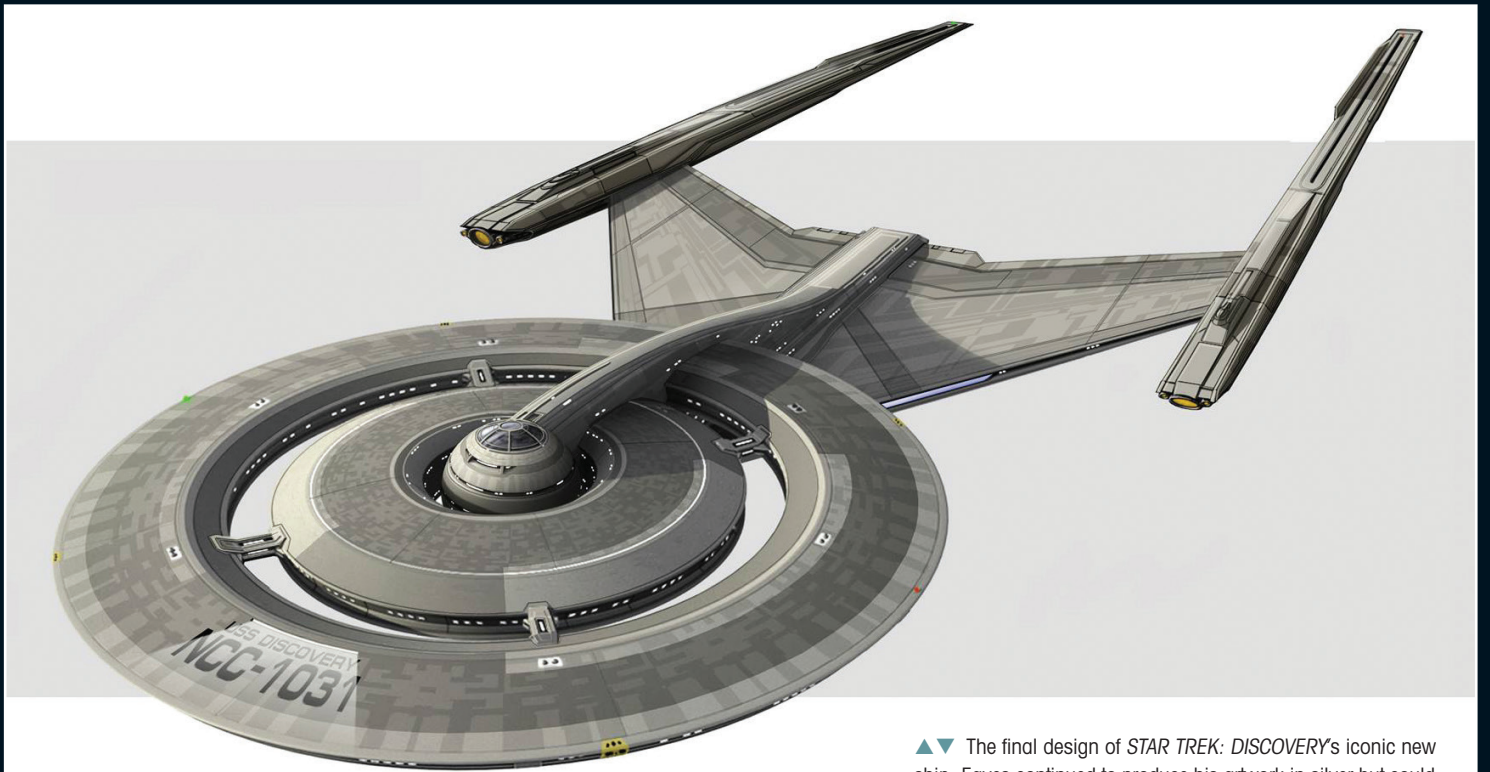

▲▼ The final design of *STAR TREK: DISCOVERY*'s iconic new ship. Eaves continued to produce his artwork in silver but could easily change the color by adding a layer in Photoshop.



# STAR TREK™

